

# Coolant

Your CRF's liquid cooling system dissipates engine heat through the coolant jacket that surrounds the cylinder and cylinder head.

Maintaining the coolant will allow the cooling system to work properly and prevent freezing, overheating, and corrosion.

## Coolant Recommendation

Use high quality ethylene glycol antifreeze containing corrosion protection inhibitors specifically recommended for use in aluminum engines. Check the antifreeze container label.

Use only distilled water as a part of the coolant solution. Water that is high in mineral content or salt may be harmful to the aluminum engine.

### NOTICE

*Using coolant with silicate inhibitors may cause premature wear of the mechanical seal or blockage of the radiator passages. Using tap water may cause engine damage.*

The factory provides a 50/50 solution of antifreeze and water in this motorcycle. This coolant solution is recommended for most operating temperatures and provides good corrosion protection.

Decreasing the concentration of antifreeze to less than 40% will not provide proper corrosion protection.

Increasing the concentration of antifreeze is not recommended because it decreases cooling system performance. Higher concentrations of antifreeze (up to 60%) should only be used to provide additional protection against freezing. Check the cooling system frequently during freezing weather.

## Checking & Adding Coolant

Refer to *Safety Precautions* on page 27.

1. With the engine cold, remove the radiator cap (1) and check coolant level. The coolant level is correct when it is at the bottom of the radiator filler neck (2).

### ⚠ WARNING

Removing the radiator cap while the engine is hot can cause the coolant to spray out, seriously scalding you.

Always let the engine and radiator cool down before removing the radiator cap.

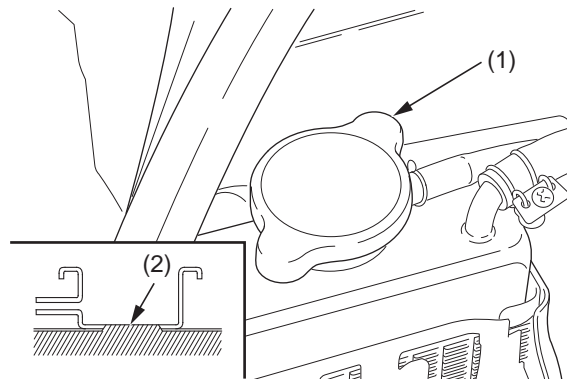

- (1) radiator cap  
(2) radiator filler neck

2. Add coolant up to the filler neck if the level is low. Inspect the coolant level before each outing. A coolant loss of 20 – 60 cm<sup>3</sup> (0.7 – 2.0 US oz, 0.7 – 2.1 Imp oz) through the over flow tube is normal. If coolant loss is more than this, inspect the cooling system.  
Capacity:  
1.06 ℓ (1.12 US qt, 0.93 Imp qt) after disassembly  
1.04 ℓ (1.10 US qt, 0.92 Imp qt) after draining
3. Install the radiator cap securely.

### NOTICE

*If the radiator cap is not installed properly, it will cause excessive coolant loss and may result in overheating and engine damage.*