

Fuel System

Installation

1. Install a new fuel pump filter (1) onto the fuel pump assembly (2) aligning its hook (3) with the joint boss (4) completely.

Be careful not to damage the hook.

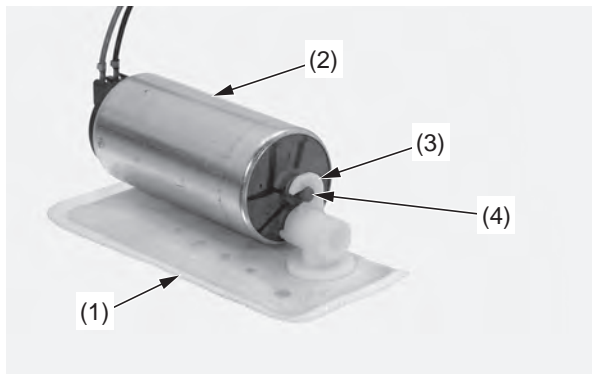

(1) new fuel pump filter
(2) fuel pump assembly
(3) hook
(4) joint boss

2. Apply small amount of silicone grease to a new O-ring (5).
Install a new O-ring to the fuel pump assembly (6).
3. Install the fuel pump assembly with fuel pump filter into the fuel pump unit holder (7) while routing the fuel pump red (8) and black (9) wires through the holder grooves (10) as shown.

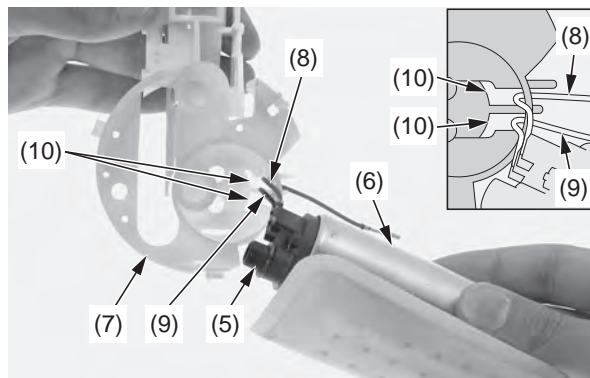

(5) new O-ring
(6) fuel pump assembly
(7) fuel pump unit holder
(8) red wire
(9) black wire
(10) grooves

4. Install a new damper rubber (11) to the fuel pump filter as shown.
Install fuel pump stopper (12).

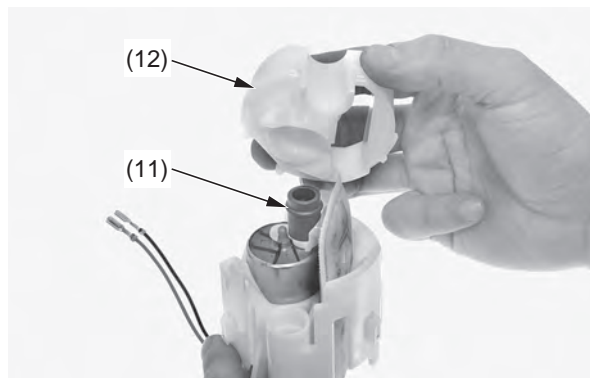

(11) new damper rubber
(12) fuel pump stopper

5. Apply small amount of silicone grease to a new O-ring (13).
Install a new O-ring to the fuel pump base (14).
6. Install the fuel pump unit holder assembly (15) into the fuel pump base while aligning its hooks (16) with the grooves (17) in the fuel pump base tabs (18).
If the gap between the hooks and tabs is more than 1.0 mm (0.04 in), replace the fuel pump unit.

Be sure that the hooks are completely seated.

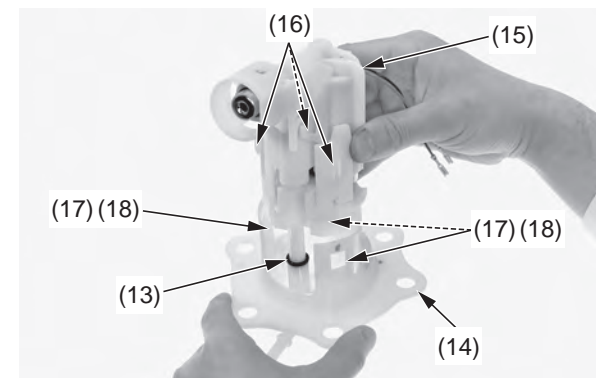

(13) new O-ring
(14) fuel pump base
(15) fuel pump unit holder assembly
(16) hooks
(17) grooves
(18) tabs