

# Fuel Tank

Refer to *Safety Precautions* on page 27.

## Removal

1. Remove the seat (page 37).
2. Remove the shroud A bolts and collars (1).
3. Remove the shroud B bolts (2) and shrouds (3).

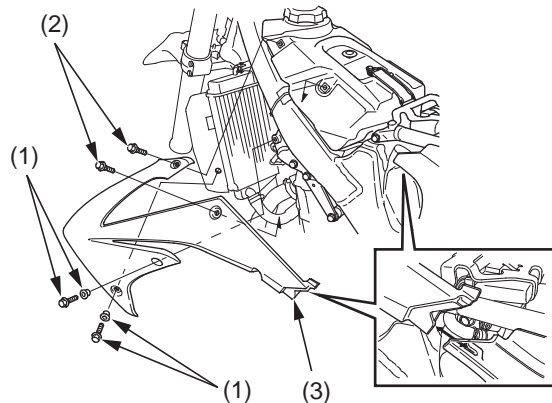

(1) shroud A bolts and collars (3) shrouds  
(2) shroud B bolts

4. Install a hose clamp (4) to the breather tube (5) and shut the hose clamp securely.

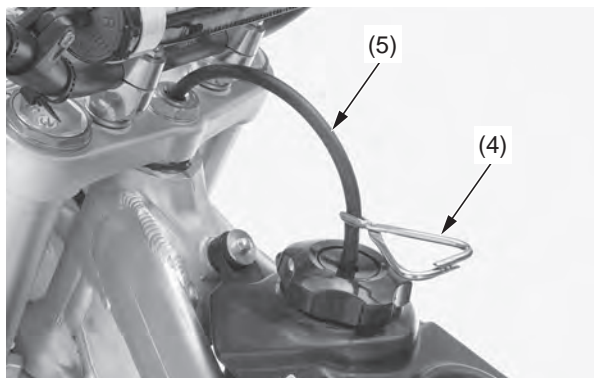

(4) hose clamp (5) breather tube

5. Pull the breather tube (5) out of steering stem nut.
6. Unhook the fuel tank band (6).

7. Remove the fuel tank bolt and collar (7).

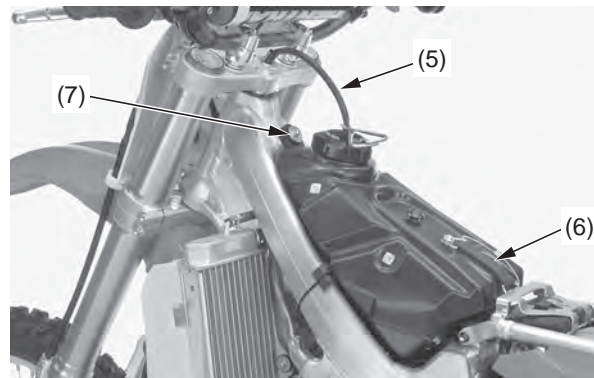

(5) breather tube  
(6) fuel tank band  
(7) fuel tank bolt and collar

8. Unhook the fuel feed hose (8) from the clamp (9).

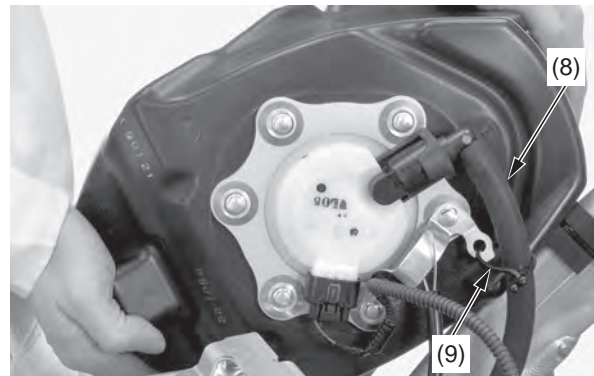

(8) fuel feed hose (9) clamp

9. Pull the fuel tank (10) out of the frame and hang it to the left of the frame. Check the fuel tank stopper cable (11) for deterioration, kinks or other damaged. Do not support the fuel tank by the fuel feed hose (8).

## ⚠ WARNING

Petrol is highly flammable and explosive. You can be burned or seriously injured when handling fuel.

- Stop the engine and keep heat, sparks and flame away.
- Handle fuel only outdoors.
- Wipe up spills immediately.

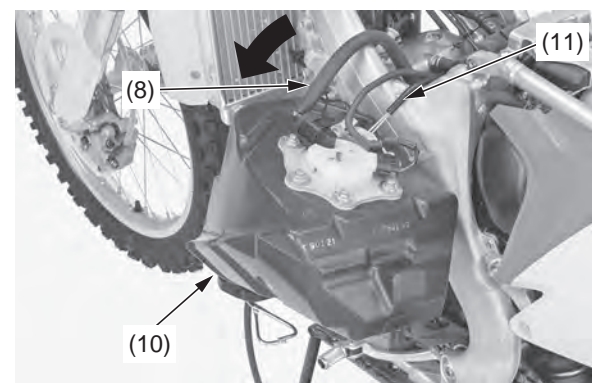

(8) fuel feed hose (11) fuel tank stopper cable  
(10) fuel tank

10. Check for interference between the frame and tank and adjust the cushion rubbers (12) if necessary.

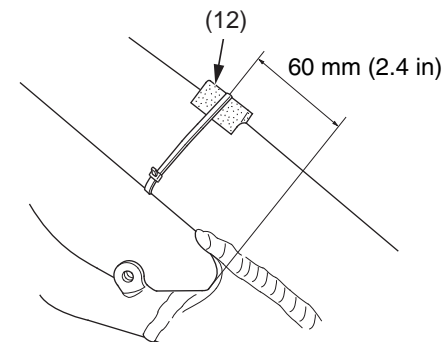

(12) cushion rubbers