

# Basic Operating Instructions

## Safe Riding Precautions

Before riding your CRF for the first time, please review the *Important Safety Precautions* beginning on page 2 and the previous section, titled *Before Riding*.

For your safety, avoid starting or operating the engine in an enclosed area such as a garage. Your CRF's exhaust contains poisonous carbon monoxide gas which can collect rapidly in an enclosed area and cause illness or death.

## Side Stand

The side stand (1) is used to support your CRF while parked (page 19). To operate, use your foot to lower the side stand until it is fully extended. Before riding, raise the side stand.

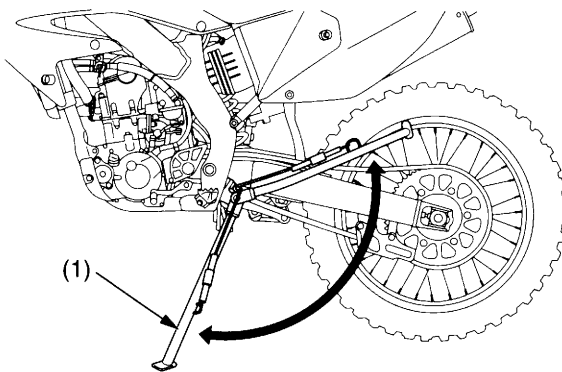

(1) side stand

## Tripmeter

The tripmeter (1) is used to record the distance traveled (USA: miles, Canada: kilometers) per trip or section of route.

To operate, pull the tripmeter reset knob (2) out (OFF) and turn it until the meter shows all zeros (0), then push the knob in (ON).

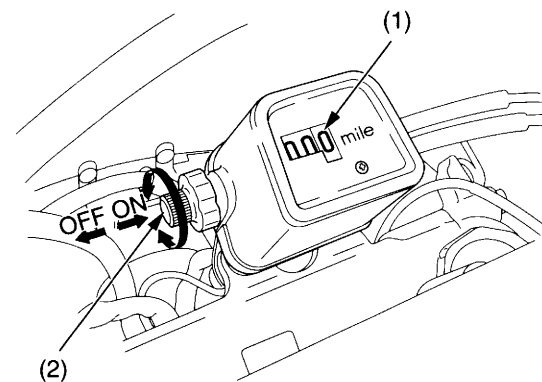

(1) tripmeter  
(2) tripmeter reset knob