

1. Remove the oil filler cap/dipstick from the right crankcase cover.
2. Place an drain pan under the crankcase.
3. Remove the oil drain plug (1), O-ring (2), spring (3) and oil strainer screen (4).
4. Clean the oil strainer screen.
5. Check that the oil strainer screen, sealing rubber and drain plug O-ring are in good condition.
6. Install the O-ring to the oil drain plug.
7. Install the oil strainer screen, spring and drain plug.

#### Oil Drain Plug Torque:

15 N·m (1.5 kgf.m, 11 lbf·ft)

8. Fill the crankcase with the recommended grade oil; approximately:  
1.0 ℓ (1.1 US qt, 0.9 Imp qt)
9. Install the oil filler cap/dipstick.
10. Start the engine and let it idle for 2 – 3 minutes.

11. Stop the engine and check that the oil level is at the upper level mark on the oil filler cap/dipstick with the motorcycle upright on firm, level ground. Make sure there are no oil leaks.

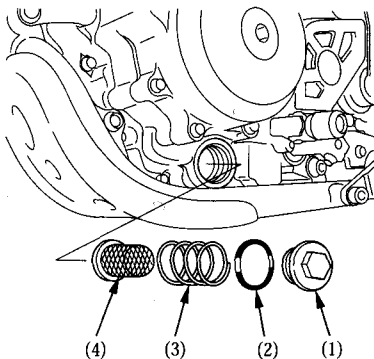

- |                    |                         |
|--------------------|-------------------------|
| (1) Oil drain plug | (3) Spring              |
| (2) O-ring         | (4) Oil strainer screen |