

Front Brake Lever:

The distance between the tip of the brake lever (1) and the grip can be adjusted by turning the adjuster (2).

Align the arrow (3) on the brake lever with the index mark (4) on the adjuster.

Apply the brake several times and check for free wheel rotation after the brake lever is released.

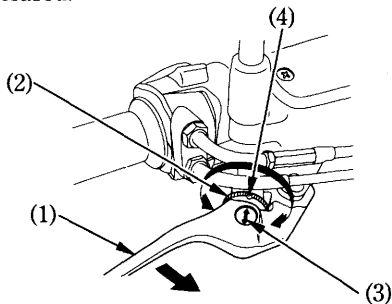

- (1) Brake lever
- (2) Adjuster

- (3) Arrow
- (4) Index mark

Other Checks:

Make sure there are no fluid leaks. Check for deterioration or cracks in the hoses and fittings.