

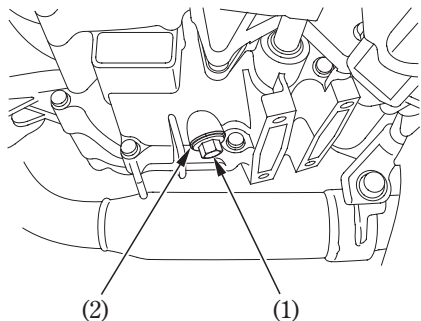

1. Place a drain pan under the crankcase.
2. To drain the oil, remove the oil fill cap/dipstick, oil drain bolt (1), and sealing washer (2).



- (1) Oil drain bolt
(2) Sealing washer

3. Check that the sealing washer on the drain bolt is in good condition and install the bolt. Replace the sealing washer every other time the oil is changed, or each time if necessary.

Engine oil drain bolt torque:

30 N·m (3.0 kgf·m , 22 lbf·ft)

4. Fill the crankcase with the recommended grade oil; approximately:
0.8 ℓ (0.8 US qt , 0.7 Imp qt)
5. Install the oil fill cap/dipstick.
6. Start the engine and let it idle for 3–5 minutes.
7. 2–3 minutes after stopping the engine, check that the oil level is at the upper level mark on the oil fill cap/dipstick with the motorcycle upright on firm, level ground. Make sure there are no oil leaks.

