

VOLTAGE INSPECTION

Connect the starter relay switch connector.
Shift the transmission into neutral.

Measure the voltage between the Yellow/Red wire (+) and ground at the starter relay switch connector.

There should be battery voltage only when the starter switch button is depressed with the ignition switch is ON.

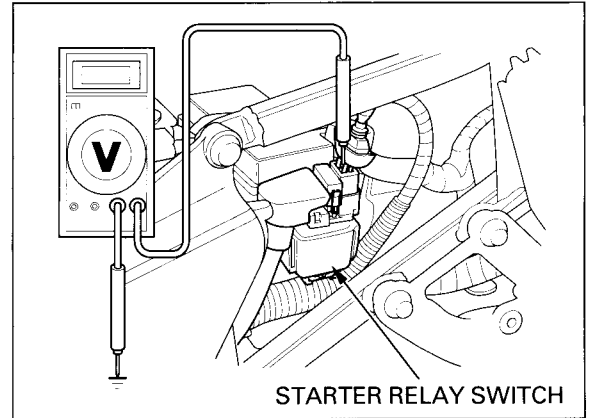

CONTINUITY INSPECTION

Disconnect the starter relay connector and cables.

Connect an ohmmeter to the starter relay switch large terminals.

Connect a fully charged 12 V battery to the starter relay switch connector terminals (Yellow/Red and Green/Red).

Check for continuity between the starter relay switch terminals.

There should be continuity while 12 V battery is connected to the starter relay switch connector terminals and should be no continuity when the battery is disconnected.

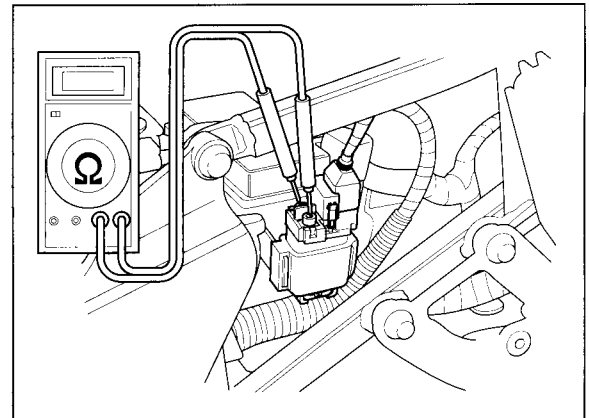

DIODE

REMOVAL

Remove the seat (page 2-2).

Open the fuse box and remove the diode.

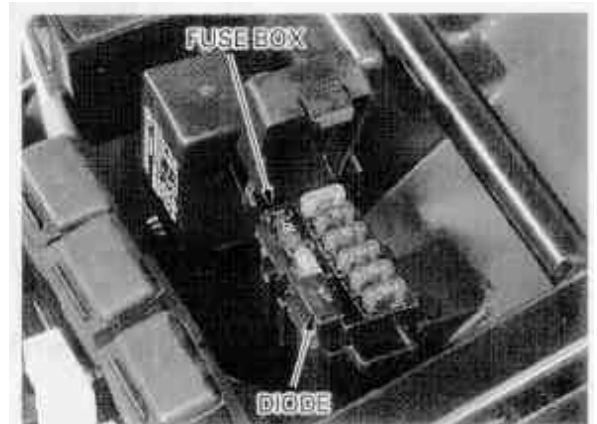

INSPECTION

Check for continuity with an ohmmeter.

Normal direction: Continuity

Reverse direction: No continuity

INSTALLATION

Install the diode in the reverse order of removal.

